

GSPVS Magnetic Drive Sump Pumps

Vertically Suspended,
Line Shaft Driven, Sealless
API 685 (as applicable)

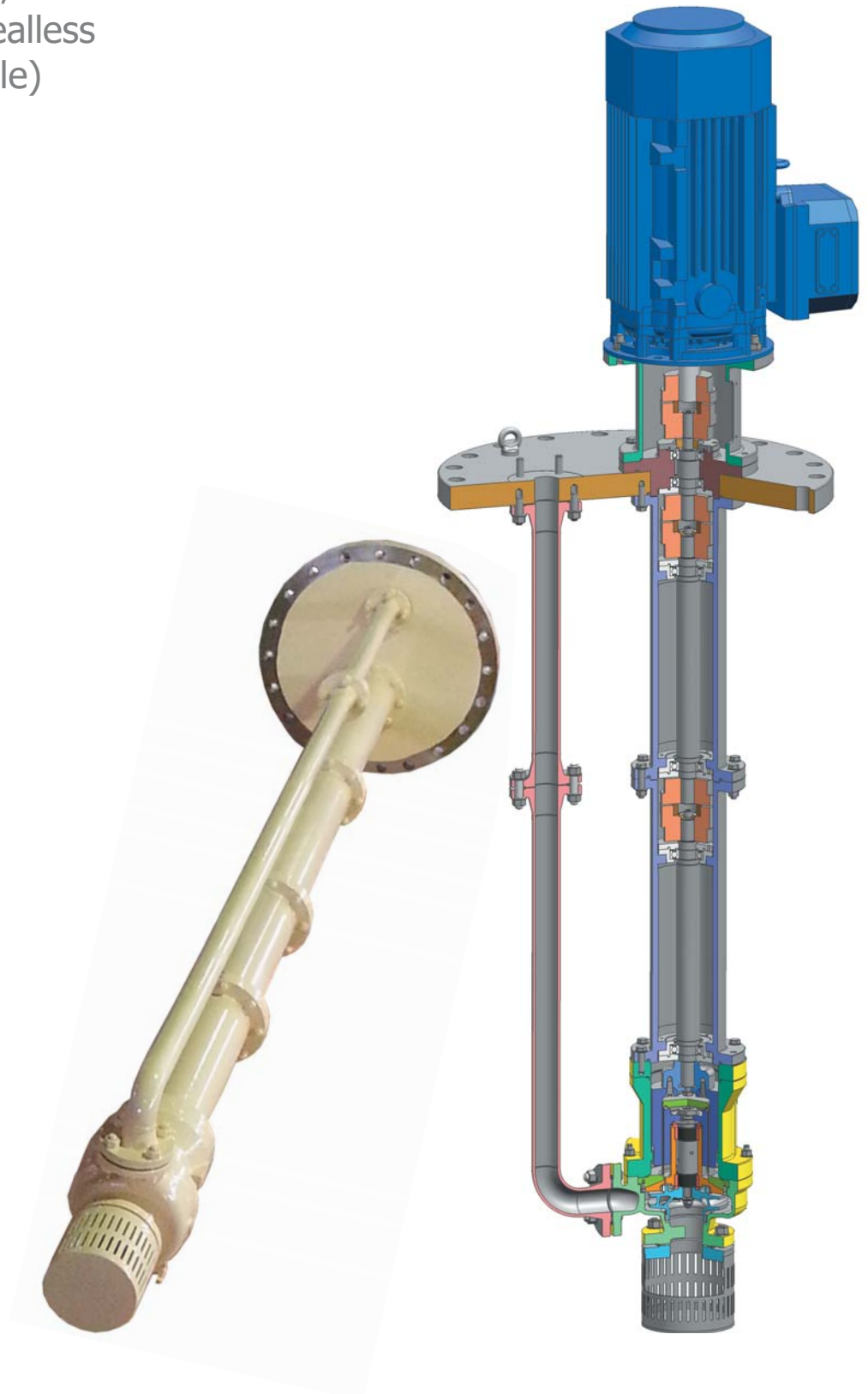

HMD Kontro



Sundyne HMD Kontro

Reduce Costs with a Sealless Sump Pump

The Sundyne HMD Kontro GSPVS (VS for Vertical Sump) Pump

All of Sundyne HMD Kontro's magnetic drive expertise in a sealless sump pump



The vertically mounted GSPVS pump provides all of the benefits of a magnetic drive sealless pump in a compact package, using fewer parts with no seal systems for reduced cost operation. The GSPVS meets the requirements of API 685 (as applicable to this style of pump) and is fully ATEX compliant, making it ideal for tank farms, oil and gas refineries, chemical and petrochemical applications.

The GPSVP is composed of modules which can be joined to reach a total assembly length up to five metres / sixteen feet and is mounted on a base available to ANSI B16.5 or to customer specific requirements, including lifting points as standard. The modular construction uses a flexible jaw coupling to join drive shafts and to absorb misalignment, decreasing vibration and increasing life expectancy.

Greased for life ball bearings are used along the column, removing the need for lubricating or cooling the intermediate sleeve bearings using system fluid. The use of labyrinth bearing seals and a suction strainer avoids external contamination to maximise seal and lubrication life.

Sundyne HMD Kontro has more than twenty-five years' experience in API applications and over a sixty-five year heritage in magnetic drive technology. Indeed, we were the first to develop a sealless pump.

With stricter demands for the safety and welfare of both personnel and the environment being imposed, our sealless pumps are playing an increasingly important role. We are continuously developing and extending our range, as improved magnet drive technology enables us to build more efficient and powerful pumps, widening the application scope of this versatile pump format.



Sundyne HMD Kontro

Vertically Suspended

Magnetic Drive Pumps

GSPVS Magnetic drive Sealless pumps offer significant advantages and benefits over conventional sealed designs:

- No seals
- No seal support systems
- Complete fluid containment
- Zero emissions
- Zero contamination of pumped liquid
- Cost effective installation
- No ancillary seal support systems to specify and install
- Longer MTBF
- No EPA monitoring required
- Improved operator safety and protection of the environment
- Small foot print

Mechanical seals are widely regarded as the weakest point in any pumping system using them. Over 85% of pump failures involve mechanical seal failure and/or leakage through static seals such as gaskets and/or O-rings and bearing failure.

When planning a new pump installation or an upgrade to an existing site, often the financial impact of the mechanical seal support system is considerable. Additional design time, utility provision, installation and commissioning is required. Once such a system is installed, further cost implications are caused by the need for new seals, replacement of barrier fluids and ongoing maintenance. Also the need to comply with local, regional or national environmental requirements, which often involve monitoring the effectiveness of such a system.

By completely eliminating the seal and associated seal support system, the HMD Kontro GSPVS range of pumps are ideal for handling liquids with the following characteristics:

- Toxic
- Lethal
- Carcinogenic
- Flammable
- Expensive Fluids
- Fluids containing dissolved solids (i.e. Caustic)
- Fluids containing H₂S (Sour Water)
- High Vapour Pressure Liquids



KEY

 Pump Casing	 Containment Shell
 Impeller	 Magnetic Drive
 Bush Holder	 Bump Ring
 Silicon Carbide Bushes	 Coupling Housing
 Silicon Carbide Shaft Sleeves and Thrust Washers	

Tank mounting plate to ANSI B16.5 flange dimensions (or to a client specific requirements).

Modular construction using flexible jaw couplings to join drive shafts and absorb misalignment.

Greased for life ball bearings remove need to lubricate/cool the intermediate sleeve bearings using system fluid.

Sleeves – concentrically located bearing sleeves. Design compensates for relative thermal expansion. Concentrically located with O-rings.

Confined controlled compression gasket.

Impellers – fully enclosed, single-piece cast with solid hubs. Keyed to the shaft.

Renewable front and rear wear rings – located by tack welding (locking pins on request).

Suction strainer ensures no oversize particles enter the pump.

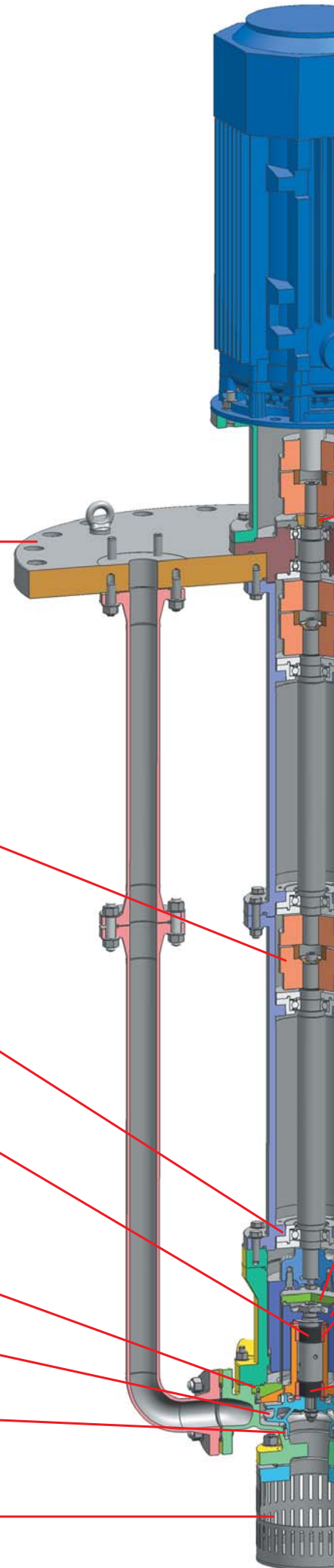



Labyrinth seal used to avoid external particles entering the column

Containment shell – constructed in accordance with ASME VIII international standards.

Powerful range of synchronous magnetic couplings.

Thrust bearings – designed for capacity in both directions.

Grooved axial and radial bearings – for heat removal and particle flushing.

Outer magnets are fully sheathed to prevent damage during assembly or disassembly.

Two radial bearings – provided as standard.

Notes

- Total assembly length up to five metres / sixteen feet
- Rapid & Economical maintenance – shoulders and dowels to facilitate assembly and disassembly.
- Temperature and pressure profiles – heat balance calculations provided.
- Materials – GSPVS pumps are available as standard with stainless steel and carbon steel materials. Other variations are available on request.
- Welding in compliance with ASME Section VIII, Div 1, and section IX.
- No special tools required
- All Magnetic Couplings feature mechanically retained and bonded magnets.
- Outer magnet rings have non-magnetic metallic sheathing to protect exposed magnets.
- All units feature a non-sparking bump ring to prevent outer magnet ring contacting containment shell in the event of an external bearing assembly failure.



Sundyne HMD Kontro

The GSPVS

Pump Range

The GSPVS range comprises pumps based on the HMD Kontro GS drive, built to API 685 as far as is applicable.

- Vertically mounted design available in five hydraulic sizes
- Large degree of interchangeability
- Commonality minimises spare parts inventory and associated costs
- Vertical suspended design
- Design ensures safe, leak free operation
- Increased efficiency via low operating costs
- Minimal spares holding and maintenance
- No costly seal support systems to specify, install or maintain
- Reduced specification time and installation costs
- Silicon carbide internal bearings
- Various flange options are available as standard
- Wide range of instrumentation systems available
- Suitable for operation at 50hz and 60hz
- Modular construction up to 5m (16ft) total assembly length
- Decreased vibration extends life expectancy
- Greased for life ball bearings remove the need for lubrication
- Fully ATEX compliant
- Suction strainer and labyrinth seals avoid external contamination
- Mounting base includes lift points as standard

Essential HMD Kontro Benefits

- High efficiency magnet drive
- Almost zero unplanned maintenance
- Absolutely no leakages
- Environmentally safe
- System pressures up to 18.9 Bar / 274 psi
- Fully encapsulated magnets
- ASME VIII containment shell
- Standard electric motors utilised
- Alpha SiC Internal Bearings
- Non Sparking Bump Ring for safety
- HMD Kontro worldwide service support

Typical Applications Include:

- Tank Farms
- Tank Fluid Transfer
- Chemical Processing Plants
- Petrochemical Processing Plants
- Storm Water and Sour Water
- Upstream - Sump + Drains
- Drainage
- HPI + CPI
- Industrial Waste Treatment
- Gas and Coal Processing
- Utilities



GSPVS Hydraulic Coverage

Head	Flow	Temperature	Design Pressure*
80 m	70 m ³ /hr	-30 to 100 °C	18.9 Bar
262 ft	308 usgpm	-20 to 210 °F	274 Psi

* Design pressures up to 40 bar (580 psi) are available on request.

Internal Pressure / Temperature Profiles Available. Optional Instrumentation Packages available.

1450 rpm

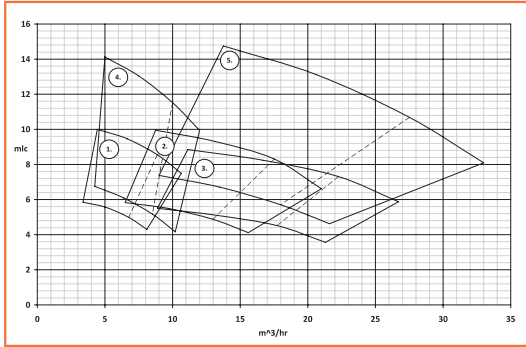

1750 rpm

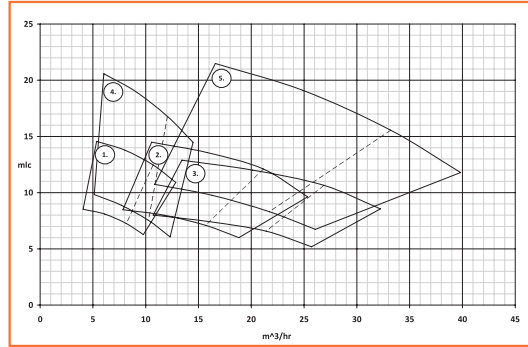

2900 rpm

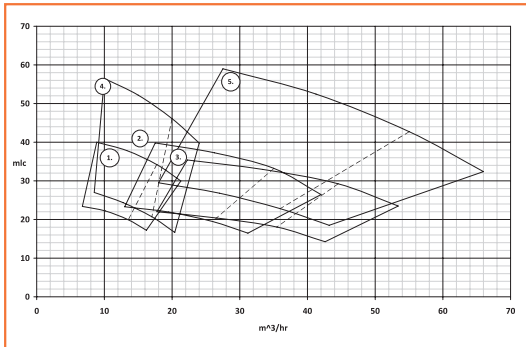

3500 rpm

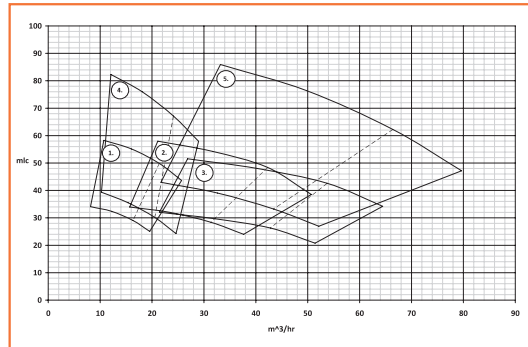

Sealless Savings

Specifying sealless, magnetic drive pumps can save significant costs both in respect of time and money. Indeed, a major feature is that savings can be made before, during and after installation, with reduced running costs.

Having no seal system, and consequently no ancillaries, means that design and engineering time as well as the time taken for procurement is significantly reduced. At the time of installation, commissioning is quicker, allowing faster project completion and there are far less lengthy HazOps (Hazard and Operability) studies to undertake, endure and agree, thanks to the much simpler design of the sealless pump.

Once up and running, sealless pumps really come into their own. Reduced downtime, because of less maintenance and no need for seal changes, contributes to much improved plant utilisation and hence profitability.

The simple design of a sealless pump, together with a proven track record, provides a 'fit and forget' advantage. Maintenance and the need for skilled labour is much reduced, plus fewer spare parts (including seals) need be stocked.

Sealless Safety

With a magnetic drive pump there is no opportunity for leaks or emissions. Because there are no seals, and the resultant leak path required to lubricate the seal, there is no need for EPA monitoring and much less risk to operational personnel.

No requirement for support systems and the fact that no barrier fluids need to be used means much reduced possibility of accidents and emissions. It also reduces liabilities and can hence also help to lower insurance costs.

Overall, sealless pumps represent better operator safety, a cleaner working environment and reduced potential for legislation and litigation.



COMPRESSORS

PUMPS

GENUINE PARTS

SERVICE

Sealless Service

Although our pumps only require minimal maintenance, that does not mean there is no after sales service from HMD Kontro. Quite the opposite in fact.

Our own After Sales team, together with our partners around the world, can help to optimise the performance and through life experience of using HMD Kontro pumps. From assisting with installation and commissioning, including ensuring smooth contract execution and swift provision of all the appropriate documentation, through to optimising your spares inventory and operating efficiency using the benefit of our experience.

Extending MTBF (mean time between failure) and providing you with the appropriate parts to effect fast maintenance and quick replacement where necessary, will significantly assist in reducing downtime and minimising through life costs, which are already inherently low with an HMD Kontro pump.

To learn more about why sealless is so suitable for your application, please contact us, either directly or through your country partner, which can be found on www.sundyne.com. We look forward to helping sealless be of service to you.

To locate the global representative, distributor or authorised service centre nearest you, or for additional information please visit www.sundyne.com

GLOBAL STRENGTH, powered by people

Representative in Moscow for Russia & FSU:

121099 Moscow, Russia
TDK Smolensky Passage
Smolenskaya Square 3, office 627
Phone: 007 (495) 234 51 01
E-mail: info@intohandel.ru
Web: www.intohandel.ru

Sundyne United Kingdom
Sundyne HMDKontro Sealless Pumps
Marshall Road
Hampden Park Industrial Estate
Eastbourne East Sussex, BN22 9AN
United Kingdom
Phone: +44 1323 452000
Fax: +44 1323 503369
Email: info@hmdkontro.com

Worldwide Sales Headquarters

Unit 2 Harvington Business Park
Brampton Road
Hampden Park Industrial Estate
Eastbourne East Sussex, BN22 9BN
United Kingdom
Phone: +44(0) 1323 452125
Fax: +44 1323 503369

All information provided is subject to change without notice.

© 2013 Sundyne, LLC
All Rights Reserved. Other logos and trade names are property of their respective owners.

HMD Kontro GSPVS 1.0 1/13 Eng.